

M.Sc. Eng. Grzegorz Barzyk
Dr Eng. Stanisław Kalisiak
Technical University of Szczecin, Poland

THE STRUCTURE OF MODERN WIND PLANTS - A VIEW OF VESTAS A/S PRODUCTS

Key words: wind plants, structure of machinery, basis of work,

Abstract: In a paper on a ground of wind plants created by Danish Vestas Wind Systems A/S described the structure and advantages of modern wind plants. Presented several methods of generator's output power control incl. OptiSlip(r)

INTRODUCTION

The wind turbines created by Danish firm Vestas Wind Systems A/S for almost twenty years now, have proven themselves to be reliable, tireless sources of environmentally friendly energy in almost every corner of the world. Actually, there are created few models, depends of power of turbine: 225, 600,660,1650kW (rated power). All models are designed in accordance with IEC 1400-1, DS472, "Germanischer Lloyd Rules and Regulations IV-None-marine Technology Part I -Wind Energy" and NEN 6096/2. In wind plants created by Vestas, the first of name's number is diameter of rotor; second of numbers, however describes the power (rated power) of generator f.e. V47-660kW means the turbine with diameter of rotor $d=47\text{m}$ and generator's power: $P=660\text{kW}$ (rated power).

MAIN COMPONENTS OF TYPICAL WIND PLANTS

The turbines in focus in this paper are a large scale horizontal axis wind power plant. The plant has a three bladed rotor and an automatic yaw system to turn the rotor into the wind. The generator is connected via thyristors (which are by-passed after cut-in using contactor) directly to a large utility grid The speed of rotation of the rotor is thereby locked to the frequency of the grid, which is of course fixed. The pitch angle of the rotor blades is adjusted by a control system. The wind energy is absorbed by the rotor and transformed to mechanical power. Via a drive train the mechanical power is delivered to generator that yields an electrical power. The electrical power will then be sent to the grid.

The nacelle contains the key components of the wind turbine, including the gearbox, and the electrical generator. Service personnel may enter the nacelle from the tower of the turbine. The nacelle is connected with the wind turbine rotor, i.e. the rotor blades via the hub.

The rotor blades capture the wind and transfer its power to the rotor hub. The most blades are made of glassfibre reinforced polyester or epoxy (GRP) each consisting of two bladeshells, glued on a supporting beam. The shortest length of blade is 9,5 m (rotor d=20m), longest: 32m (rotor d=66m). Vestas is also one of the world makes the blades in Prepreg technique.(the shortest blade in Prepreg production is 23 m long). Prepreg , a fibre glass product that is pre-impregnated with epoxy, was introduced instead of the old method in wind turbines with $P > 660\text{kW}$. The fatigue of repeated bending is a several million times. They must endure more than 135.000 operating hours.

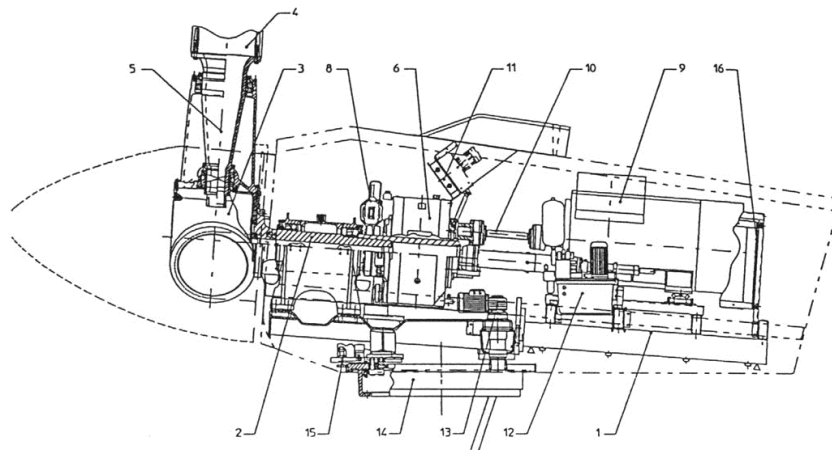

Fig. 1 Structure of machinery

The hub of the rotor is attached to the low speed shaft of the wind turbine.

The low speed shaft of the wind turbine connects the rotor hub to the gearbox. On a 600 kW wind turbine the rotor rotates relatively slowly, about 19 to 30 revolutions per minute (RPM). The shaft contains pipes for the hydraulics system to enable the aerodynamic brakes to operate.

The gearbox makes the high speed shaft approximately 50 times faster than the low speed shaft. The high speed shaft rotates with approximately. 1,500 RPM and drives the electrical generator. It is equipped with an emergency mechanical disc brake. The mechanical brake is used in case of failure of the aerodynamic brake, or when the turbine is being serviced.

The gearbox depends od type of turbine. For example in V29-225kW is two stage with parallels shafts, in V66-1,65MW is combined planetary and helical gearbox.

The electrical generator is usually an induction generator or asynchronous generator. In case of greater power (660kW and more), the turbine is equipped with two generators in order to lower the noise level and increase the yearly output. At wind speeds lower than approx. 7m/s the turbine will have the secondary generator to the grid giving rotor speed of approx. 15 rpm reducing the noise emission significantly. The V47-660 kW has been developed with due consideration of its immediate surroundings. The turbine uses a dual generator system in which a small generator is operational up to a wind speed of 7 m/s. This means reduced noise in conditions where this is most important. In case of turbines with lower power (225kW), the generator is changeable between 8 poles as "the little generator" and 6 poles as "the big generator", then, the rotor has two different speeds depending on which number of poles there are connected (this is done to achieve a max. performance both at low and high wind speeds).

Yawing is done by yawing motors, which meshes with a big toothed wheel mounted on the top of the tower.

The wind turbine controller consists of a number of computers which continuously monitor the condition of the wind turbine and collect statistics on its operation. The controller also controls: switches, hydraulic pumps, valves, yawing and motors within the wind turbine.

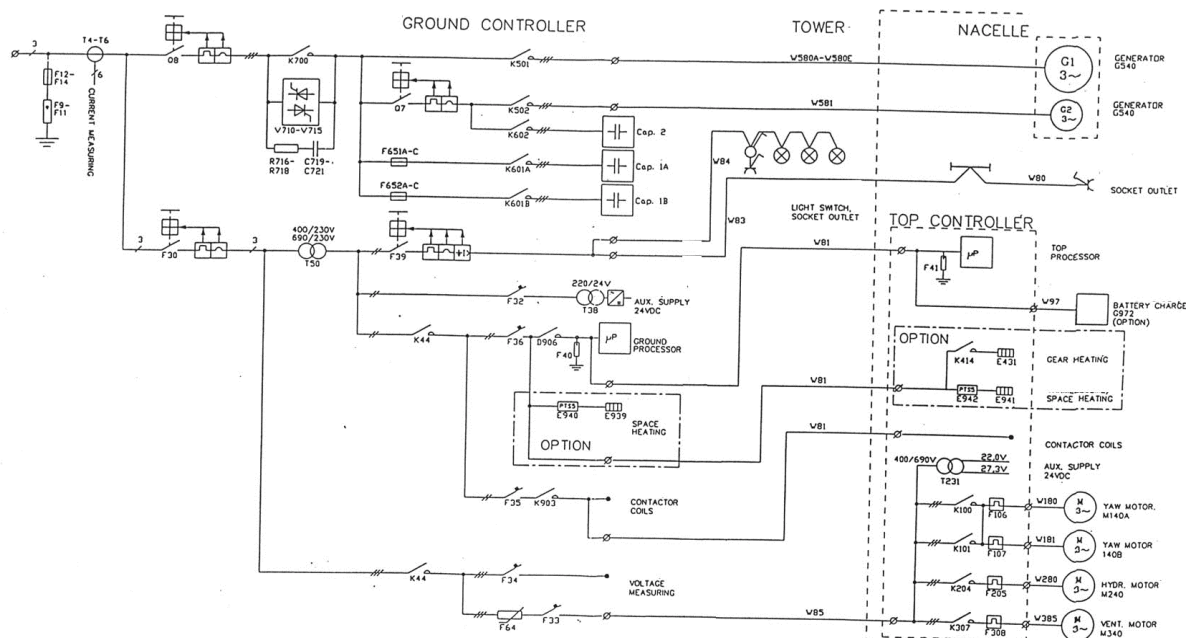

whole blades or blades tips. Passive control results from blade profiles that produce aerodynamic stall at high wind speeds without a change of blade pitch.

Regulation, achieved by controlling the power extracted by the rotor, is necessary since there is little opportunity to store excess energy within the turbine (although there is very short term storage in large machines due to inertia of the rotor and drive train, and small variations in rotor speed). The philosophy of turbine control is based on three operational requirements:

The generation of maximum power up to rated power

Satisfactory electrical power quality

The minimisation of variable and transient loads (especially fatigue inducing changing loads), thereby maximising turbine life

To achieve below presented requirements, in wind turbines are used the regulation's methods:

Stall regulation, Active pitch regulation, Load Control, Yaw Control

Stall regulation.

Passive control relies on the turbine's inherent machine characteristics, where the aerodynamic properties of the rotor limit the torque produced at high wind speeds. In stall regulation, control of the rotor power is achieved by exploiting the stall characteristics of the rotor blade. A blade is said to stall when the laminar flow over the airfoil breaks down and the blade loses lift. This is analogous to an aircraft wing "stalling" when there is no longer sufficient lift to counteract gravity. This happens at low speed relative to the air. The blade is designed in such a way that at the higher wind speeds, the stall conditions occur progressively from the root tip. The higher the wind speed, the greater the section of blade in stall. The appeal of this form of regulation is the lack of moving parts or of an active control system. The rotor blades of stall-controlled wind turbines are bolted to the hub at a fixed angle. The geometry of the rotor blade profile is aerodynamically designed to ensure that when the wind speed becomes too high, turbulence created on the side of the rotor blade not facing the wind. This turbulence creates the stall effect, which reduces the lifting force of the rotor blades and the amount of power generated. Reducing stall-induced vibrations and ensuring a stable power curve at all times are among the main problem to be solved.

Pitch regulation. The blades of pitch-regulated turbines automatically adjust themselves to the wind velocity. This is done by means of an electronic controller that checks the power of the turbine several times per second (turning blades slightly out of the wind or into the wind). Usually, the blades are pitched a fraction of a degree at a time while the rotor keeps turning.

OptiTip(r) regulation. It ensures the perfect blade angle for the various wind conditions. The Microprocessor-based controll unit is constantly monitored wind speed and measure the

turbine's output, adjusting the blade settings to ensure the optimal energy production level. The OptiTip(r) system guarantees the perfect balance between optimum performance and minimal noise levels.

OptiSlip(r) regulation The elasticity of the OptiSlip(r) system allows the speed of rotation of both generator and rotor to vary by as much as 10% during a gust of wind. This not only helps eliminates flickering, but also minimises the strain on the main components of the wind turbine. This prolongs the service life of the turbines vital parts and the higher power quality pleases the power stations. The asynchronous OptiSlip(r) generator utilises a computerised system that can create a variable slip of as much as 10%. This means that the speed of both the blades and the generator can vary by as much as 10% and therefore cope with even the strongest gusts of wind without passing fluctuations on to the grid. In strong winds the OptiSlip(r) generator keeps the power output at a constant nominal power output. In addition, the mechanical strain on the mechanical parts of the turbine is kept to an absolute minimum. Until quite recently, sudden gusts of wind were extremely tough on the mechanical components of wind turbines, and have caused undesirable fluctuations on the grid. Now this problem is a thing of the past, thanks to the OptiSlip(r) system from Vestas. Combined with the OptiTip(r) pitch adjustment system, OptiSlip(r) gives Vestas' 600 kW turbines the most effective and reliable performance available in the field of wind turbine technology.

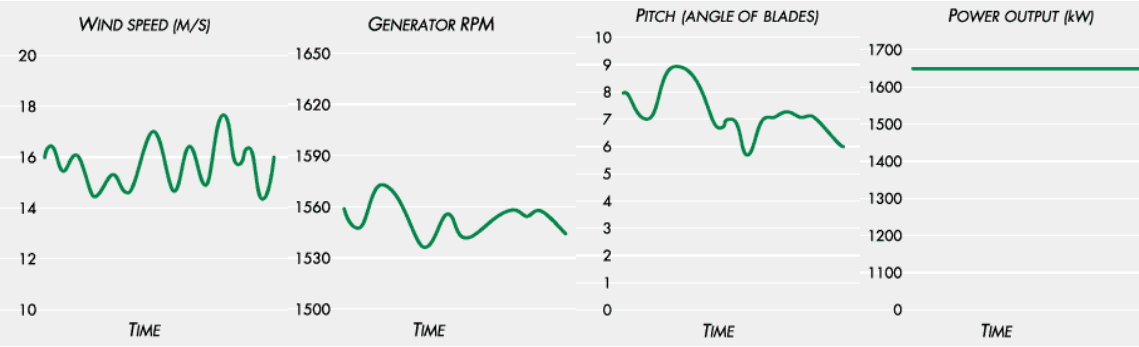

With the present technology the answer was found to be a combination of the two known generator principles - applying new technology to a tried and tested method to open a wide range of new possibilities. The result of this research and development work is the OptiSlip(r) concept, now a standard feature of all Vestas wind turbines from 600 kW and upwards.

In summary, the advantage of OptiSlip(r) is that, when combined with pitch regulation, it allows the wind turbine to operate at maximum output without creating flickers or power fluctuations, while at the same time reducing mechanical wear and tear, and increasing the useful life of the turbine. The concept allows the speed of rotation of both generator and rotor to vary by as much as 10% during sudden gusts of wind, thereby minimising unwanted fluctuations in the grid. The elasticity inherent in the OptiSlip(r) system also minimises the strain on the main components of the wind turbine.

ADVANTAGES OF VESTAS A/S WIND TURBINES

The new V47-660 kW from Vestas is dangerous as such - untamed perhaps, and certainly in its element in the great outdoors. The new design allows the blades to cut so aggressively through the wind that the kilowatt counter runs as much as between 17-19 % faster than even its highly competitive predecessor. Development work on this turbine has focused on one factor: profitability. The rotor diameter is 47 metres and the blades are designed with a level of structural flexibility which allows them to actually bend under the force of the wind. This design, combined with the OptiSlip(r) generator system, significantly reduces the wear and tear on the turbine's vital components.

THE SOUND PROTECTION

Vestas' new V66-1.65 MW turbine sets new standards for noise levels in the heavyweight class. Despite being the world's largest commercial wind turbine, the V66-1.65 MW has been developed and designed to show due consideration for its surroundings.

To achieve this we have used a two-generator technique in our latest flagship. This technique makes it possible for the turbine to operate at low wind speeds with a small generator, resulting in a noise level of 99 dBA; at high speeds the turbine switches automatically to a larger generator with a noise level of just 102.5 dBA - and this generator also ranks among the very quietest in the megawatt class of wind turbines.

The larger of the two generators is, of course, equipped with Vestas' unique OptiSlip™ system. This not only minimises strain on the turbine's machinery during sudden gusts of wind, but also improves the power quality produced.

LIGHTNING PROTECTION

Total Lightning Protection, which is used in Vestas 600 kW, 660 kW and 1.65 MW turbines protect them from the tips of their blades down to their foundations in accordance with the most stringent of the four classes under the IEC 1024-1 protection regulations. Though wind turbines are not often struck by lightning, the taller the turbine tower, the greater the chance of it happening. And no matter how effectively a turbine is protected, it is impossible to eliminate completely the risk of it being struck. Therefore, it is not a question of avoiding lightning, but more a question of controlling and conducting it through the turbine and tower construction - and thus minimize possible damage.

If the worst comes to the worst and a wind turbine is struck by lightning, the lightning will always take the route with the best conductivity, i.e. the least resistance. The Vestas Total Lightning Protection uses this in the form of a special 'lightning route' through the turbine. Lightning is led from the tip of the blade, down to the hub from where it is led through the nacelle and the tower down into the ground.

LOW TEMPERATURE VERSION

Some of the Vestas wind turbines are created also in Low Temperature version. It is a very important especially in North European conditions. For example, one of the most repeating problems in wind plant (NTK 750) in Lisewo, Poland is icing of wind speed and wind direction sensors and poor lubrication (in winter conditions) of nacelle rotation system.

This low temperature version is equipped with a special heat treated steel components when necessary, and the nacelle has built in heaters. Also the wind vane and anemometer are heated. Other modifications have also been necessary to enable this version to operate down to -30° C. This version is designed for a temperature range from -30° C to +40° C. (Standard -20° C to +40° C). It 's becuse of the higher density of air at low temperatures, the LT version has lower extreme wind speed limits, (approx. 2 m/s lower as 10 min. Average and 3m/s lower as 3 sec. Gust).

REFERENCES

Papers of VESTAS Wind turbines, Item no. 941521.R3; 941534.R1; 941615.R4; 941608.R2;
943117.R0; 943511.R4, 943516.R4; Vestas Wind Systems A/S 1994-1998

The WINDow no. 3, Vestas A/S; January 1999

Danish Wind Turbine Manufacturers Association Web Site; <http://www.windpower.dk>

Bradley S. Chadwick H.; AMSET Wind Energy Training Course of De Montfort University,
Great Britain 1996

Kaiser K; Aerodynamic Damping for Flexible Structures; BWEA 19; Edinburgh July 1997